



## *Installation Instructions*

# **POINT I/O Synchronous Serial Interface Absolute Encoder Module**

Catalog Number 1734-SSI, Series C

### **Inside . . .**

<b>For</b>	<b>See Page</b>
Important User Information	2
Preventing Electrostatic Discharge	3
Environment and Enclosure	4
North American Hazardous Location Approval	5
European Hazardous Location Approval	6
About the Module	7
Install the Mounting Base	8
Install the Module	10
Install the Removable Terminal Block (RTB)	12
Remove a Mounting Base	13
Wire the Module	15
Configure the Module	17
Troubleshoot	19
Specifications	22

### Important User Information





Solid state equipment has operational characteristics differing from those of electromechanical equipment. *Safety Guidelines for the Application, Installation and Maintenance of Solid State Controls* (Publication SGI-1.1 available from your local Rockwell Automation sales office or online at <http://www.literature.rockwellautomation.com>) describes some important differences between solid state equipment and hard-wired electromechanical devices. Because of this difference, and also because of the wide variety of uses for solid state equipment, all persons responsible for applying this equipment must satisfy themselves that each intended application of this equipment is acceptable. In no event will Rockwell Automation, Inc. be responsible or liable for indirect or consequential damages resulting from the use or application of this equipment.

The examples and diagrams in this manual are included solely for illustrative purposes. Because of the many variables and requirements associated with any particular installation, Rockwell Automation, Inc. cannot assume responsibility or liability for actual use based on the examples and diagrams.

No patent liability is assumed by Rockwell Automation, Inc. with respect to use of information, circuits, equipment, or software described in this manual.

Reproduction of the contents of this manual, in whole or in part, without written permission of Rockwell Automation, Inc., is prohibited.

Throughout this manual, when necessary, we use notes to make you aware of safety considerations.

<b>WARNING</b> 	Identifies information about practices or circumstances that can cause an explosion in a hazardous environment, which may lead to personal injury or death, property damage, or economic loss.
<b>IMPORTANT</b>	Identifies information that is critical for successful application and understanding of the product.
<b>ATTENTION</b> 	Identifies information about practices or circumstances that can lead to personal injury or death, property damage, or economic loss. Attentions help you identify a hazard, avoid a hazard and recognize the consequences.
<b>SHOCK HAZARD</b> 	Labels may be located on or inside the equipment (e.g., drive or motor) to alert people that dangerous voltage may be present.
<b>BURN HAZARD</b> 	Labels may be located on or inside the equipment (e.g., drive or motor) to alert people that surfaces may be dangerous temperatures.

## Preventing Electrostatic Discharge

---

**ATTENTION**

This equipment is sensitive to electrostatic discharge, which can cause internal damage and affect normal operation. Follow these guidelines when you handle this equipment:

- Touch a grounded object to discharge potential static.
  - Wear an approved grounding wriststrap.
  - Do not touch connectors or pins on component boards.
  - Do not touch circuit components inside the equipment.
  - If available, use a static-safe workstation.
  - When not in use, store the equipment in appropriate static-safe packaging.
-

## Environment and Enclosure

---

**ATTENTION**



This equipment is intended for use in a Pollution Degree 2 industrial environment, in overvoltage Category II applications (as defined in IEC publication 60664-1), at altitudes up to 2000 meters without derating.

This equipment is considered Group 1, Class A industrial equipment according to IEC/CISPR Publication 11.



Without appropriate precautions, there may be potential difficulties ensuring electromagnetic compatibility in other environments due to conducted as well as radiated disturbance.

This equipment is supplied as “open type” equipment. It must be mounted within an enclosure that is suitably designed for those specific environmental conditions that will be present and appropriately designed to prevent personal injury resulting from accessibility to live parts. The interior of the enclosure must be accessible only by the use of a tool. Subsequent sections of this publication may contain additional information regarding specific enclosure type ratings that are required to comply with certain product safety certifications.

See NEMA Standards publication 250 and IEC publication 60529, as applicable, for explanations of the degrees of protection provided by different types of enclosure. Also, see the appropriate sections in this publication, as well as the Allen-Bradley publication 1770-4.1 (“Industrial Automation Wiring and Grounding Guidelines”), for additional installation requirements pertaining to this equipment.

---

## North American Hazardous Location Approval

<p><b>The following information applies when operating this equipment in hazardous locations:</b></p>	<p><b>Informations sur l'utilisation de cet équipement en environnements dangereux:</b></p>
<p>Products marked "CL I, DIV 2, GP A, B, C, D" are suitable for use in Class I Division 2 Groups A, B, C, D, Hazardous Locations and nonhazardous locations only. Each product is supplied with markings on the rating nameplate indicating the hazardous location temperature code. When combining products within a system, the most adverse temperature code (lowest "T" number) may be used to help determine the overall temperature code of the system. Combinations of equipment in your system are subject to investigation by the local Authority Having Jurisdiction at the time of installation.</p>	<p>Les produits marqués "CL I, DIV 2, GP A, B, C, D" ne conviennent qu'à une utilisation en environnements de Classe I Division 2 Groupes A, B, C, D dangereux et non dangereux. Chaque produit est livré avec des marquages sur sa plaque d'identification qui indiquent le code de température pour les environnements dangereux. Lorsque plusieurs produits sont combinés dans un système, le code de température le plus défavorable (code de température le plus faible) peut être utilisé pour déterminer le code de température global du système. Les combinaisons d'équipements dans le système sont sujettes à inspection par les autorités locales qualifiées au moment de l'installation.</p>
<p><b>WARNING</b></p> 	<p><b>EXPLOSION HAZARD -</b></p> <ul style="list-style-type: none"> <li>• Do not disconnect equipment unless power has been removed or the area is known to be nonhazardous.</li> <li>• Do not disconnect connections to this equipment unless power has been removed or the area is known to be nonhazardous. Secure any external connections that mate to this equipment by using screws, sliding latches, threaded connectors, or other means provided with this product.</li> <li>• Substitution of components may impair suitability for Class I, Division 2.</li> <li>• If this product contains batteries, they must only be changed in an area known to be nonhazardous.</li> </ul>
<p><b>AVERTISSEMENT</b></p> 	<p><b>RISQUE D'EXPLOSION –</b></p> <ul style="list-style-type: none"> <li>• Couper le courant ou s'assurer que l'environnement est classé non dangereux avant de débrancher l'équipement.</li> <li>• Couper le courant ou s'assurer que l'environnement est classé non dangereux avant de débrancher les connecteurs. Fixer tous les connecteurs externes reliés à cet équipement à l'aide de vis, loquets coulissants, connecteurs filetés ou autres moyens fournis avec ce produit.</li> <li>• La substitution de composants peut rendre cet équipement inadapté à une utilisation en environnement de Classe 1, Division 2.</li> <li>• S'assurer que l'environnement est classé non dangereux avant de changer les piles.</li> </ul>

## European Hazardous Location Approval

---

### European Zone 2 Certification (The following applies when the product bears the EEx marking.)

This equipment is intended for use in potentially explosive atmospheres as defined by European Union Directive 94/9/EC.

DEMKO certifies that this equipment has been found to comply with the Essential Health and Safety Requirements relating to the design and construction of Category 3 equipment intended for use in potentially explosive atmospheres, given in Annex II to this Directive.

The examination and test results are recorded in confidential report No 03NK30347.

Compliance with the Essential Health and Safety Requirements has been assured by compliance with EN 50021.

---

#### IMPORTANT

Observe the following additional Zone 2 certification requirements.

- This equipment is not resistant to sunlight or other sources of UV radiation.
  - The secondary of a current transformer shall not be open-circuited when applied in Class I, Zone 2 environments.
  - Equipment of lesser Enclosure Type Rating must be installed in an enclosure providing at least IP54 protection when applied in Class I, Zone 2 environments.
  - This equipment shall be used within its specified ratings defined by Allen-Bradley.
  - Provision shall be made to prevent the rated voltage from being exceeded by transient disturbances of more than 40% when applied in Class I, Zone 2 environments.
-

## About the Module

Use this Series C module with the following:

- ControlNet adapter with RSLogix 5000 software, version 11 or higher
- DeviceNet adapter
- EtherNet/IP adapter with RSLogix 5000 software, version 11 or higher
- PROFIBUS adapter

This module collects serial data from industrial absolute-position encoding sensors that use standard SSI protocol. You insert the module into a POINT I/O terminal base that provides common power, communication, and wiring connections for the SSI sensors.

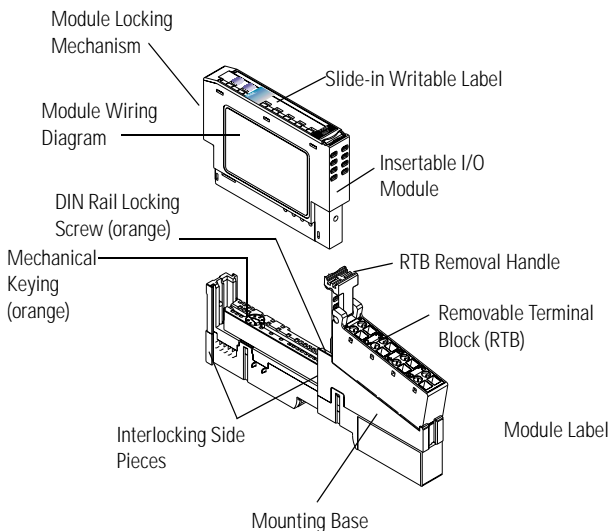

43122

## Install the Mounting Base

To install the mounting base on the DIN rail, proceed as follows.

---

**ATTENTION**



POINT I/O is grounded through the DIN rail to chassis ground. Use zinc plated yellow-chromate steel DIN rail to assure proper grounding. The use of other DIN rail material (e.g., aluminum, plastic, etc.) that can corrode, oxidize, or are poor conductors, can result in improper or intermittent grounding.

Secure DIN rail to mounting surface approximately every 200 mm (7.8 inches).

---

1. Position the mounting base vertically above the installed units (adapter, power supply, or existing module).
2. Slide the mounting base down to engage the interlocking side pieces with the adjacent module or adapter.



3. Press firmly to seat the mounting base on the DIN rail.

The mounting base snaps into place.

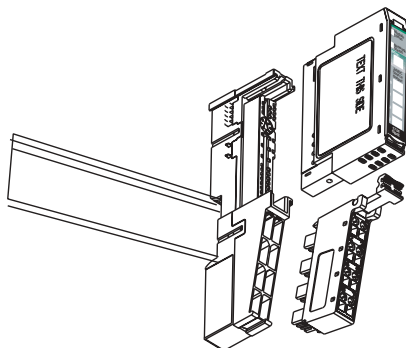

44013

To remove the mounting base from the DIN rail, proceed as follows.

1. Remove the module.
2. Use a small-bladed screwdriver to rotate the base locking screw to a vertical position.

This releases the locking mechanism.

3. Lift straight up to remove.

## Install the Module

---

**WARNING**



When you insert or remove the module while backplane power is on, an electrical arc can occur. This could cause an explosion in hazardous location installations.

Be sure that power is removed or the area is nonhazardous before proceeding. Repeated electrical arcing causes excessive wear to contacts on both the module and its mating connector. Worn contacts may create electrical resistance that can affect module operation.

---

Install the module before or after base installation. Be sure that you complete the following.

- Correctly key the mounting base before installing the module into the mounting base.
- Position the mounting base locking screw horizontal referenced to the base.

To install the module on the DIN rail, proceed as follows.

1. Use a bladed screwdriver to rotate the keyswitch on the mounting base clockwise until the number required for the type of module being installed aligns with the notch in the base.

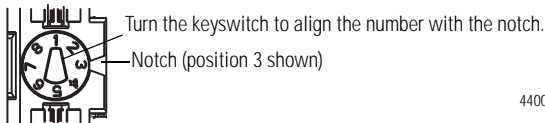

44009

2. Be sure the DIN rail locking screw is in the horizontal position.

If you unlock the locking mechanism, you cannot insert the module.

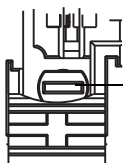

Be sure the DIN rail locking screw is in the horizontal position.

44010

3. Insert the module straight down into the mounting base.

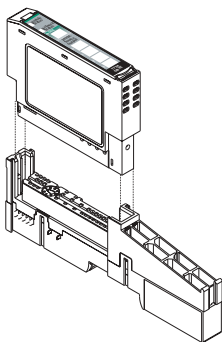

44012

4. Press to secure.

The module locks into place.

## Install the Removable Terminal Block (RTB)

A removable terminal block comes with your wiring base. To remove, pull up on the RTB handle. Remove or replace the mounting base without removing any of the wiring.

**WARNING**



When you connect or disconnect the removable terminal block (RTB) with field-side power applied, an electrical arc can occur. This could cause an explosion in hazardous location installations.

Be sure that power is removed or the area is nonhazardous before proceeding.

1. Insert the end opposite the handle into the base unit.

This end has a curved section that engages with the wiring base.

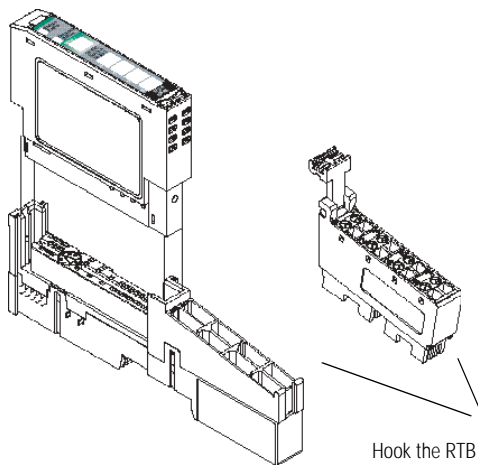

Hook the RTB end into the mounting base end, and rotate until it locks into place.

44011

2. Rotate the terminal block into the wiring base until it locks itself in place.
3. If you installed an I/O module, snap the RTB handle into place on the module.

## Remove a Mounting Base

To remove a module from the DIN rail, remove any installed module and the removable terminal block, if wired.

1. Unlatch the RTB handle on the I/O module.
2. Pull on the RTB handle to remove the removable terminal block.

---

**WARNING**

When you connect or disconnect the removable terminal block (RTB) with field-side power applied, an electrical arc can occur. This could cause an explosion in hazardous location installations.

Be sure that power is removed or the area is nonhazardous before proceeding.

---

3. Press on the module lock on the top of the module.

4. Pull on the I/O module to remove from the base.
- 

**WARNING**



When you insert or remove the module while backplane power is on, an electrical arc can occur. This could cause an explosion in hazardous location installations.

Be sure that power is removed or the area is nonhazardous before proceeding. Repeated electrical arcing causes excessive wear to contacts on both the module and its mating connector. Worn contacts may create electrical resistance that can affect module operation.

---

5. Use a small-bladed screwdriver to rotate the orange, base-locking screw to a vertical position.

This releases the locking mechanism.

6. Lift straight up to remove.

## Wire the Module

**WARNING**



If you connect or disconnect wiring while the field-side power is on, an electrical arc can occur. This could cause an explosion in hazardous location installations. Be sure that power is removed or the area is nonhazardous before proceeding.

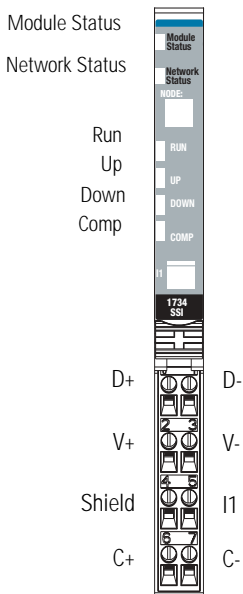

43123

D = Data  
C = Clock

I1 = Digital Sourcing Input 1  
V = SSI Sensor

0 D+	1 D-
2 V+	3 V-
4 Shield	5 I1
6 C+	7 C-

43124

D = Data  
C = Clock

I1 = Digital Sourcing Input 1  
V = SSI Sensor

---

### Module Terminations

0	D+ <sup>(1)</sup>
1	D- <sup>(1)</sup>
2	V+
3	V-
4	Shield
5	I1
6	C+ <sup>(1)</sup>
7	C- <sup>(1)</sup>

<sup>(1)</sup>D and C are RS422-type differential pairs.



## Configure the Module

The module transmits SSI sensor data over the DeviceNet network. You exchange data with the master through a polled, cyclic, or change-of-state connection.

The module does not support Bit-Strobe Command Response Messaging and the Unconnected Message Manager (UCMM)<sup>(1)</sup>.

The module produces and consumes data as follows.

I/O Connection Type	Consumes	Produces
Polled	2 bytes	10 bytes
Cyclic	2 bytes	10 bytes
Change-of-State	2 bytes	10 bytes

### Consume and Produce Bit/Byte Definitions

Byte	Bit	Description
Produce 0	0-7	Low byte of present low SSI word. Bit 0 is the least significant bit of the entire present SSI word.
Produce 1	0-7	High byte of present low SSI word.
Produce 2	0-7	Low byte of present high SSI word.
Produce 3	0-7	High byte of present high SSI word. Bit 7 is the most significant bit of the entire present SSI word.
Produce 4	0-7	Low byte of stored low SSI word. Bit 0 is the least significant bit of the entire stored SSI word.

<sup>(1)</sup> If you are not familiar with these terms, see the DeviceNet Specification for definitions (online: [www.odva.org](http://www.odva.org)).

**Consume and Produce Bit/Byte Definitions**

Byte	Bit	Description
Produce 5	0-7	High byte of stored low SSI word.
Produce 6	0-7	Low byte of stored high SSI word.
Produce 7	0-7	High byte of stored high SSI word. Bit 7 is the most significant bit of the entire stored SSI word.

**Consume and Produce Bit/Byte Definitions**

Byte	Bit								Description
	7	6	5	4	3	2	1	0	
Produce 8	7	6	5	4	3	2	1	0	Status Byte 0 <sup>(1)</sup>
	C2ST	C1ST	C2R	C1R	INC	DEC	RUN	I1	
Produce 9	7	6	5	4	3	2	1	0	Status Byte 1 <sup>(2)</sup>
	RES	RES	RES	LHON	IDF <sup>2</sup>	CCE	CCF	SPF	

<sup>(1)</sup> For detailed descriptions of these bits, see 1734-SSI User Manual, publication 1734-UM009.

<sup>(2)</sup> Monitor IDF to determine the validity of the produced data. If IDF=1, the SSI data is false.

### Consume and Produce Bit/Byte Definitions

Byte	Bit								Description
Consume 0	7	6	5	4	3	2	1	0	Master ACK Byte <sup>(1)</sup>
	RES	RES	RES	SCMP2	SCMP1	CC2	CC1	LACK	
Consume 1	7	6	5	4	3	2	1	0	CONS1
	RES	RES	RES	RES	RES	RES	RES	RES	

<sup>(1)</sup> The master must provide the Master ACK Byte to receive the polled Produced bytes 0-9.

## Troubleshoot

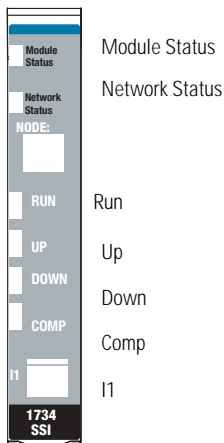

43125

Indication	Probable Cause
<b>Module Status</b>	
Off	No power applied to device.
Green	Device is operating normally.
Flashing Green	Device needs commissioning due to configuration missing, incomplete or incorrect.
Flashing Red	Recoverable fault is present.
Red	Unrecoverable fault may require device replacement.
Flashing Red/Green	Device is in self-test.

Indication	Probable Cause
<b>Module Status</b>	
Off	No power applied to device.
Green	Device is operating normally.
Flashing Green	Device needs commissioning due to configuration missing, incomplete, or incorrect.
Flashing Red	Recoverable fault is present.
Red	Unrecoverable fault may require device replacement.
Flashing Red/Green	Device is in self-test.

<b>Network Status</b>	
Off	Device is not online. - Device has not completed dup_MAC_id test. - Device not powered - check module status indicator.
Flashing Green	Device is online but has no connections in the established state.
Green	Device online and has connections in the established state.
Flashing Red	One or more I/O connections are in timed-out state.

<b>Indication</b>	<b>Probable Cause</b>
Red	Critical link failure - failed communication device is present. Device detected error that prevents it communicating on the network.
Flashing Red/Green	Communication faulted device - the device has detected a network access error and is in communication faulted state. Device has received and accepted an Identify Communication Faulted Request - long protocol message.
<b>Run Status</b>	
Off	Module is commanded to stop retrieving SSI data.
Green	Module is commanded to retrieve SSI data.
<b>Up Status</b>	
Off	SSI data not increasing, or no SSI data is being received.
Green	SSI data is increasing.
<b>Down Status</b>	
Off	SSI data not decreasing, or no SSI data is being received.
Green	SSI data is decreasing.
<b>Comp Status</b>	
Off	Comparator function is not in use, or comparator value not attained.
Green	Comparator value attained.
<b>I1 Status</b>	
Off	Latching input I1 is OFF.
Yellow	Latching input I1 is ON.

## Specifications

### 1734-SSI POINT I/O Synchronous Serial Absolute Encoder Module

Specification	Value
Number of SSI Channels	1
Encoder Type	Any absolute encoder supporting standard SSI protocol including linear, rotary, and optical distance measuring devices Most-Significant Bit Aligned data format Physical interface for clock and data signals is RS-422.
Module Location	1734-TB, 1734-TBS wiring base assembly
Keyswitch Position	2
POINTBus Current	110 mA @ 5V dc
Power Dissipation	0.94 W
Isolation Voltage (continuous-voltage withstand rating)	50V continuous Tested to withstand 1250V ac for 60 s
Dimensions	HxWxL 56.0 x 12.0 x 75.5 mm (2.21 x 0.47 x 2.97 in)
Weight	0.032 kg (0.07 lb)
SSI Data Rate	125 kHz, 250 kHz, 500 kHz, 1 MHz, 2 MHz (software selectable)
SSI Bits Per Word	2...31 (software selectable)
SSI Word Delay Time <sup>(1)</sup>	16 $\mu$ s...64 ms (software selectable)
SSI Word Length	4 bytes (32 bits)
SSI Features	Gray or binary code capable with gray to binary conversion, increasing or decreasing SSI count indication, 2 SSI word comparator values, SSI word latching with I1 input
SSI Position Forming Time <sup>(2)</sup>	$\geq$ 0.5 ms

**1734-SSI POINT I/O Synchronous Serial Absolute Encoder Module**

Specification	Value
SSI Cable Type	UL CM/AWM 2464/CSA Type CMG FT4 or similar cable utilizing shielded twisted pairs for D+/- and C+/- connections. See sensor manufacturer for actual cable required for the SSI sensor under use. I1 input can be separate from SSI cable.
SSI Cable Length	Depends on desired SSI data rate: 125 kHz - 1050 ft (320 m) 250 kHz - 525 ft (160 m) 500 kHz - 195 ft (60 m) 1 MHz - 65 ft (20 m) 2 MHz - 25 ft (8 m)
SSI Sensor Power (At V+/- Terminals)	10...28.8V dc common with field power voltage, 0.75A dc maximum with short circuit protection
SSI Clock Drive Current (Out of C+/- Terminals)	125 mA maximum
Input I1	IEC Type 3 voltage and current characteristics, sourcing type <u>Minimum</u> <u>Nominal</u> <u>Maximum</u>
ON-State Voltage	0V dc      --      FPV* -10
ON-State Current	2 mA      4 mA      5 mA (FPV=24V dc)
OFF-State Voltage	FPV-5      --      FPV
OFF-State Current	1.2 mA      --      --
Input Impedance	--      3.6 k $\Omega$ 4.7 k $\Omega$
Input Filter Time	--      0.5 ms      --
	* = FPV Field Power Supply Voltage
Field Power Supply Voltage (Bus Supply)	<u>Minimum</u> <u>Nominal</u> <u>Maximum</u> 10V dc      24V dc      28.8V dc
LED Indicators	All powered from the logic side
User Manual	1734-UM007

- (1) Time between successive SSI words (Tp). Also called Dwell Time.
- (2) Roughly corresponds to the maximum time the SSI sensor can be expected to output a particular position value while in motion. To use the 1734-SSI module with sensors that have faster position forming times, change the SSI Word Filter Control parameter from its default value of 5 (max). Changing this parameter from its default value sacrifices electrical noise environment performance for sensor data conversion speed.

### Environmental Specifications

Specification	Value
Operational Temperature	IEC 60068-2-1 (Test Ad, Operating Cold), IEC 60068-2-2 (Test Bd, Operating Dry Heat), IEC 60068-2-14 (Test Nb, Operating Thermal Shock) -20...55 °C (-4...131 °F)
Storage Temperature	IEC60068-2-1 (Test Ab, Unpackaged Non-operating Cold) IEC60068-2-2 (Test Bb, Unpackaged Non-operating Dry Heat) IEC60068-2-14 (Test Na, Unpackaged Non-operating Thermal Shock) -40...85 °C (-40...185 °F)
Relative Humidity	IEC60068-2-30 (Test Db, Unpackaged Non-operating Damp Heat) 5...95% non-condensing
Vibration	IEC 60068-2-6 (Test Fc, Operating) 5 g @ 10-500 Hz
Shock Operating	IEC60068-2-27 (Test Ea, Unpackaged Shock) 30 g
Shock Non-operating	IEC60068-2-27 (Test Ea, Unpackaged Shock) 50 g
Emissions	CISPR 11: Group 1, Class A
ESD Immunity	IEC6100-4-2 6 kV contact discharges 8 kV air discharges



## Environmental Specifications

Radiated RF Immunity	IEC 61000-4-3 10 V/m with 1KHz sine-wave 80%AM from 30 MHz to 2000 MHz 10 V/m with 200Hz 50% Pulse 100%AM at 900 MHz
EFT/B Immunity	IEC 61000-4-4 +2 kV at 5.0 kHz on signal ports
Surge Transient Immunity	IEC 61000-4-5 $\pm 1$ kV line-line (DM) and $\pm 2$ kV line-earth (CM) on signal ports $\pm 2$ kV line-earth (CM) on shielded ports
Conducted RF Immunity	IEC61000-4-6 10 Vrms with 1 kHz sine-wave 80%AM from 150 kHz to 80 MHz
Enclosure Type Rating	None (open-style)
Wire Size	#22...#14 AWG (0.324...2.08 sq. mm) solid or stranded copper wire rated @ 75 °C or greater 3/64 in (1.2 mm) insulation maximum
Wiring Category <sup>(1)</sup>	2 - on signal ports
Wire Type	Copper Shielded on encoder port
Terminal Base Screw Torque	7 lb-in (0.6 Nm) maximum

<sup>(1)</sup> Use this conductor category information for planning conductor routing as described in publication 1770-4.1, "Industrial Automation Wiring and Grounding Guidelines."

## Certification

Certification	Value
Certification <sup>(1)</sup> (when product is marked)	c-UL-us UL Listed for Class I, Division 2, Group A,B,C,D Hazardous Locations, certified for U.S. and Canada CE European Union 89/336/EEC EMC Directive, compliant with: EN 50082-2; Industrial Immunity EN 61326; Meas./Control/Lab., Industrial Requirements EN 61000-6-2; Industrial Immunity EN 61000-6-4; Industrial Emissions C-Tick Australian Radiocommunications Act, compliant with: AS/NZS CISPR11; Industrial Emissions EEx European Union 94/9/EC ATEX Directive, compliant with: EN 50021; Potentially Explosive Atmospheres, Protection "n" (Zone 2)

<sup>(1)</sup> See the Product Certification link at [www.ab.com](http://www.ab.com) for Declarations of Conformity, Certificates, and other certification details.

POINT I/O and POINTBus are trademarks of Rockwell Automation.  
 ControlNet is a trademark of ControlNet International, Ltd.  
 DeviceNet is a trademark of the Open DeviceNet Vendor Association.

## Notes:

## Rockwell Automation Support

Rockwell Automation provides technical information on the web to assist you in using its products. At <http://support.rockwellautomation.com>, you can find technical manuals, a knowledge base of FAQs, technical and application notes, sample code and links to software service packs, and a MySupport feature that you can customize to make the best use of these tools.

For an additional level of technical phone support for installation, configuration and troubleshooting, we offer TechConnect Support programs. For more information, contact your local distributor or Rockwell Automation representative, or visit <http://support.rockwellautomation.com>.

## Installation Assistance

If you experience a problem with a hardware module within the first 24 hours of installation, please review the information that's contained in this manual. You can also contact a special Customer Support number for initial help in getting your module up and running:

United States	1.440.646.3223 Monday – Friday, 8am – 5pm EST
Outside United States	Please contact your local Rockwell Automation representative for any technical support issues.

## New Product Satisfaction Return

Rockwell tests all of its products to ensure that they are fully operational when shipped from the manufacturing facility. However, if your product is not functioning and needs to be returned:

United States	Contact your distributor. You must provide a Customer Support case number (see phone number above to obtain one) to your distributor in order to complete the return process.
Outside United States	Please contact your local Rockwell Automation representative for return procedure.

[www.rockwellautomation.com](http://www.rockwellautomation.com)

### Power, Control and Information Solutions Headquarters

Americas: Rockwell Automation, 1201 South Second Street, Milwaukee, WI 53204-2496 USA, Tel: (1) 414.382.2000, Fax: (1) 414.382.4444  
Europe/Middle East/Africa: Rockwell Automation, Vorstlaan/Boulevard du Souverain 36, 1170 Brussels, Belgium, Tel: (32) 2 663 0600, Fax: (32) 2 663 0640  
Asia Pacific: Rockwell Automation, Level 14, Core F, Cyberport 3, 100 Cyberport Road, Hong Kong, Tel: (852) 2887 4788, Fax: (852) 2508 1846

Publication 1734-IN581C-EN-E - June 2005

PN 957955-75

Supersedes Publication 1734-IN581B-EN-P - May 2003

Copyright © 2005 Rockwell Automation, Inc. All rights reserved. Printed in the U.S.A.